

Application Note *How to use the TOMBAK as a burst generator*

Multiboard Series

TOMBAK : Synchronization electronic board



How to use the TOMBAK as a burst generator

Pre-requirement: Before using the TOMBAK board, make sure you followed all the instructions mentioned in the Operating Manual

1. Presentation

The board can generate a burst signal from an external trigger or from a software trigger.

The burst consists of a specific software adjustable number of pulses.

When triggered, the board output a burst signal with an adjustable pulse width, a specific delay and a frequency related to the "Pulse In" input signal.

2. Timing Diagram



Figure 1 : Burst signal of 3 pulses, "Gate-IN" or Soft triggered and "Pulse-In" synchronized

3. Synoptic

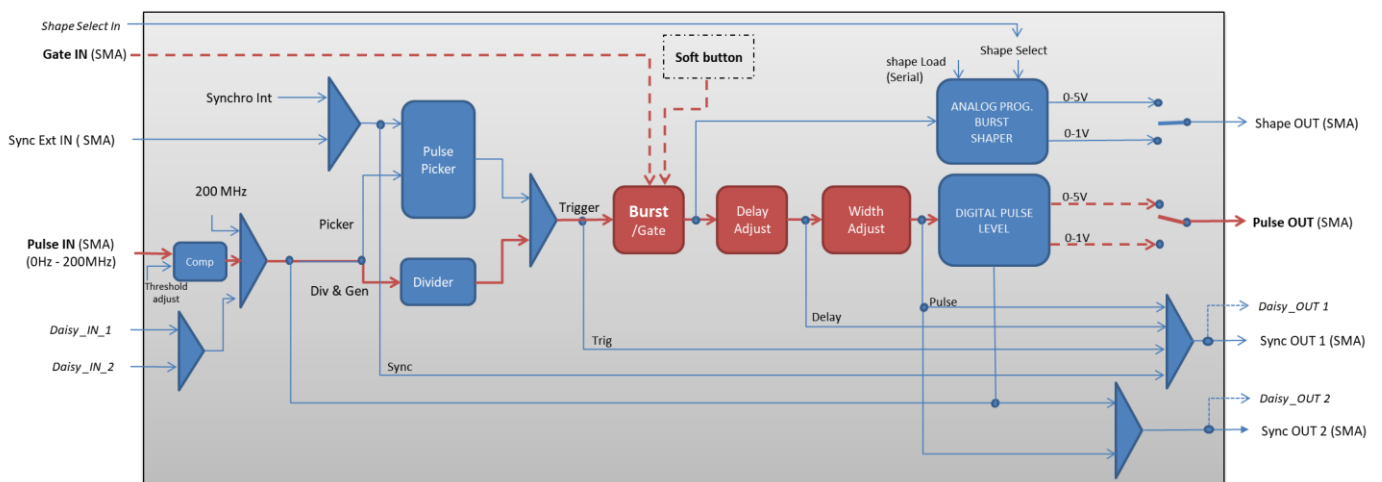
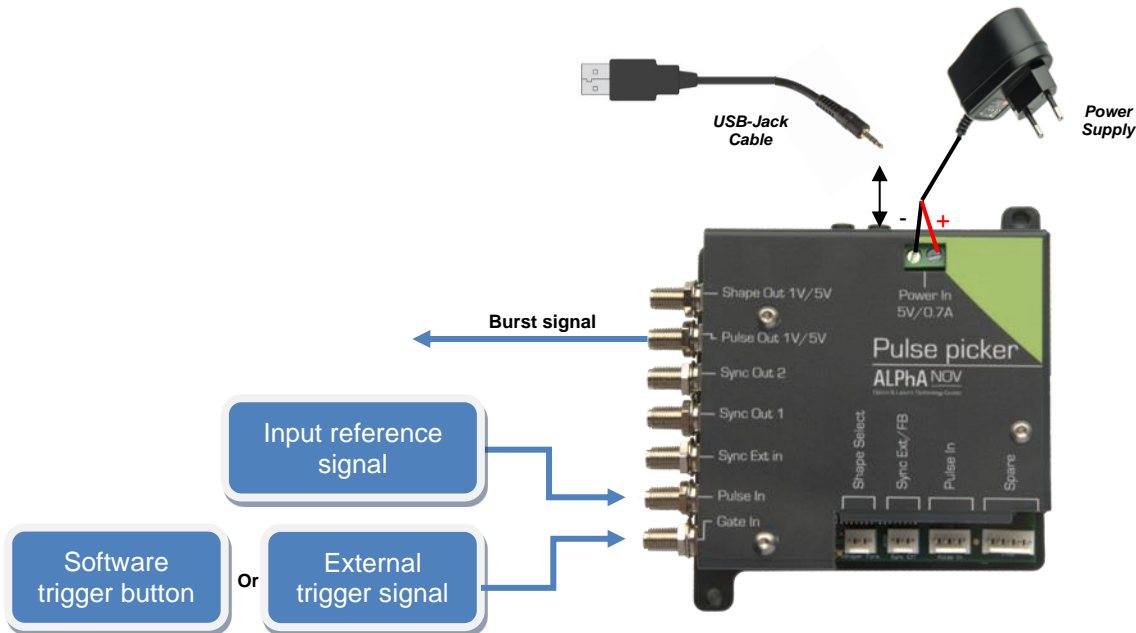

Figure 2 : Main software features used in Burst Generator

4. Cabling

1. Plug the USB-Jack cable in the “USB In” connector
2. Plug the power supply to the “Power In” connector to power on the board
3. Burst signal will output on the “Pulse Out” SMA connector
4. Connect the trigger signal that will start the burst to “Gate In” SMA connector
5. Connect the reference signal (i.e. the signal that will drive the burst when triggered) to “Pulse In” SMA connector.



5. Software configuration

Launch the ALPhANOV Control Software and click on *Connect* to start the TOMBAK hardware detection. The software automatically detects the TOMBAK board.

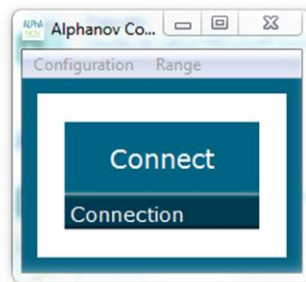

A window will appear for each TOMBAK connected to the computer.

The main configuration windows must be configured as follow :

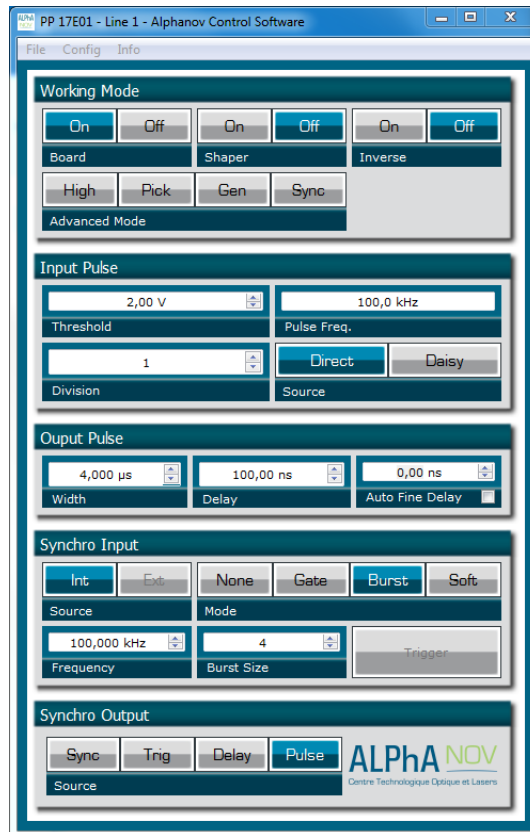

- Working Mode window :
 - Set the **Board** button to **ON**
 - Set the **Shaper** button to **Off**
 - Set the **Inverse** button to **Off**
 - Unset all **Advance Mode**

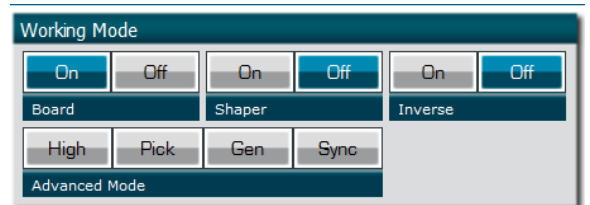

- Input pulse window :
 - Configure the **Threshold** voltage so that the input pulse frequency is detected and the same as your pulse generator system
 - Set the **Division** factor to **1** (default settings). Division value may be adjusted to divide the input reference signal frequency.
 - Set the input pulse **Source** to **Direct**

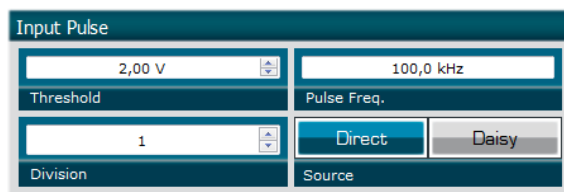

- Output Pulse window :
 - Set the output pulse **Width**
 - Set the **Delay** between output and input signals
 - **AutoFineDelay** may be let in auto mode

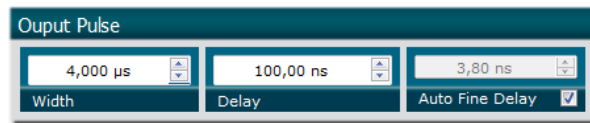

- Synchro input windows:
 - **Source** synchronisation is not used in this mode
 - Set **Mode** to Burst
 - **Frequency** is not used in this mode
 - Set the **Burst Size** value to configure the number of pulse triggered

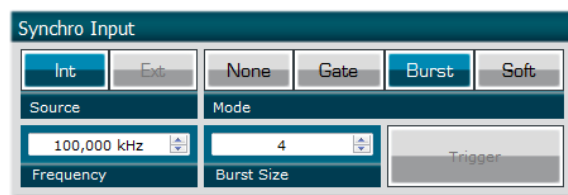

- Synchro output window (default settings) :
 - Source : Pulse



Don't forget to save the settings by clicking on the "Save" button in the bar menu.

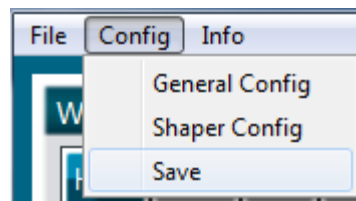

6. Main feature

Burst size range	[1 - 10 ⁹] pulses
Adjustable pulse width ⇒ resolution (pulse width [5ns – 510ns]) ⇒ resolution (pulse width [511ns – 2 ⁶² ns])	[5ns – >>1000s] 2ns 5ns
Adjustable pulse delay ⇒ resolution	[70ns – >>1000s] 10ps
Input Trigger Voltage ⇒ Logic Low ⇒ Logic High	[0-0.8V] [1.7-3.3V]
Input PulseIn voltage	30 mV – 3,3V
Output Voltage	1 / 3,3 / 5 Volts (hardware setup)
Output maximum frequency	20 MHz